

Giunti a PIOLI

Tassello rimovibile senza arretrare le macchine

Versione in acciaio C45

Certificato ATEX

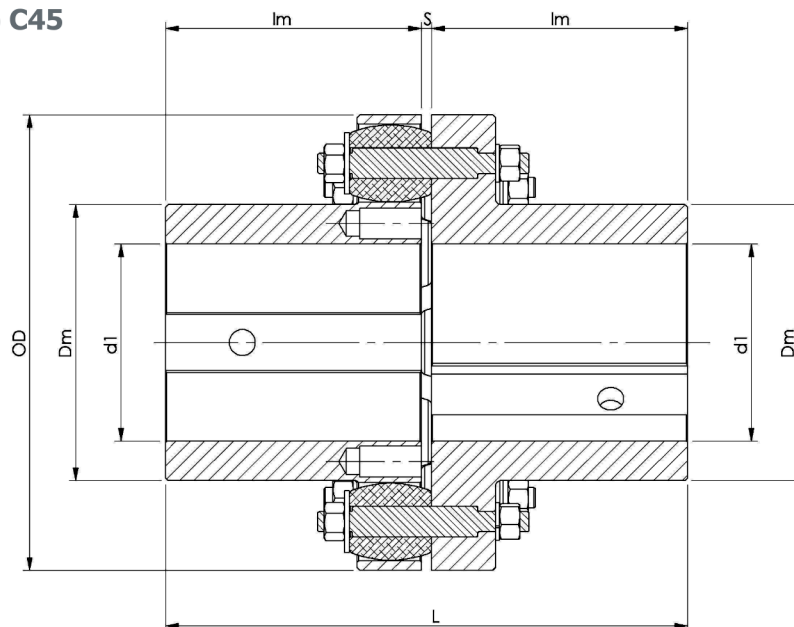

Taglia	TkN	Tk max	Foro massimo d1	OD	Db	L	lm	S	Peso
	Nm	Nm	mm						
PL088	100	200	26	88	39	113	55	3	2,3
PL098	230	460	38	98	55	123	60	3	3,6
PL118	360	720	48	118	71	143	70	3	6
PL138	610	1220	60	138	85	163	80	3	8,9
PL158	950	1900	70	158	102	183	90	3	13,9
PL178	1300	2600	72	178	103	204	100	4	17,8
PL198	1850	3700	80	198	116	234	115	4	24,5
PL228	2700	5400	100	228	145	264	130	4	36,5
PL248	4700	9400	120	248	170	305	150	5	50
PL298	6500	13000	130	298	182	365	180	5	85
PL348	11000	22000	140	348	200	406	200	6	132
PL398	15000	30000	165	398	232	446	220	6	187
PL445	21500	43000	180	445	253	487	240	7	258
PL495	29000	58000	205	495	288	527	260	7	348
PL545	38000	76000	230	545	322	567	280	7	456
PL625	77000	154000	265	625	375	567	280	7	644
PL675	96000	192000	280	675	405	587	290	7	765
PL790	140000	280000	300	790	420	607	300	7	965