

Giunti Lamellari LMD

ATEX, 6 FORI

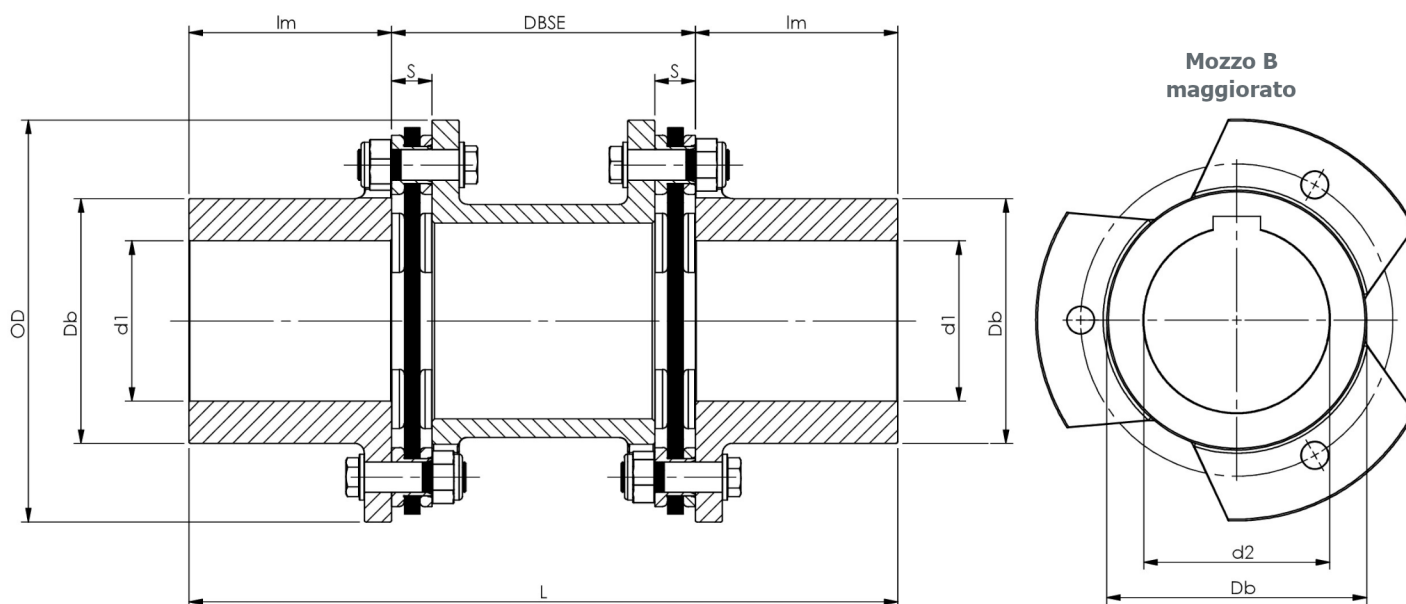

Taglia	Coppia Nom.	Potenza	Giri massimi	Mozzo S	Mozzo B	OD	Db Mozzo S	Db Mozzo B	L	Im	S	DBSE	Peso	Momento d'inerzia
				foro max d1	foro max d2									
	Nm	kW/rpm	giri/min	mm	mm	mm	mm	mm	mm	mm	mm	mm	kg	Kgm ²
LMD0012	120	0,0122	35000	32	34	79	45	48	136	35	8	66	1,7	0,0009
LMD0018	175	0,0178	31000	38	42	90	55	59	146	40	8	66	2,6	0,0018
LMD0032	320	0,0326	25000	45	50	108	64	70	169	45	10	79	3,5	0,0051
LMD0072	720	0,0734	19000	53	58	135	75	83	209	55	12	99	7,5	0,0111
LMD0120	1150	0,1172	16000	65	75	160	92	103	251	65	13	121	14	0,0306
LMD0180	1800	0,1835	14000	80	85	176	112	119	270	70	14	130	20	0,0553
LMD0280	2800	0,2854	11000	92	95	206	130	135	311	90	15	131	31	0,1133
LMD0430	4250	0,4332	9000	96	100	227	135	140	400	110	22	180	45	0,2140
LMD0590	5900	0,6014	9000	102	110	238	145	154	420	120	24	180	52	0,2483
LMD0704	7040	0,7176	8500	112	120	255	160	170	420	120	25	180	69	0,4208
LMD0910	9100	0,9276	7500	125	128	294	175	180	460	130	28	200	91	0,7134
LMD1250	12450	1,2691	6500	138	142	316	195	200	500	140	32	220	122	1,1358
LMD1600	15900	1,6208	6000	150	156	338	210	220	520	150	32	220	148	1,5985